

CAT500 series

Circuit Breaker Analyzers & Timers

- Simultaneous timing, static resistance and dynamic resistance measurement on up to 12 main contacts interrupting chambers under BSG conditions by use of CAT modules
- Saves testing time by single cable connection and simultaneous measurement
- Timing, motion and vibrations measurement
- Minimum trip voltage (MTV) test
- GIS Module for timing measurement of single pole-controlled GIS under BSG conditions
- 10.1" graphical touch-screen color interface



Description

The **CAT500** is a new high-end Circuit Breaker Analyzer & Timer designed for condition assessments of all types of medium and high voltage circuit breakers.

Graphical touchscreen 10.1-inch color interface provides easy and intuitive setup, execution and test result analysis.

Simultaneous timing, static (contact) resistance and dynamic resistance measurement of up to 12 interrupting chambers of live tank circuit breakers can be obtained with **CAT Modules (optional feature)**.

CAT500 series provides an easy selection of different operational modes:

- Open (O)
- Close (C)
- Reclose (O-0,3s-C)
- Trip free (CO)
- O-0,3s-CO
- Open-Close (O-C)
- Close-Open (C-O)
- Open-Close-Open (O-C-O)

Multiple operations, such as Open-Close and Open-Close-Open, can be initiated by using a predefined delay time or by sensing a breaker's contact position.

The six coil control analog channels can measure and record coil currents simultaneously (OPEN and CLOSE), up to 35 A AC/DC.

The circuit breaker operation can be initiated in different ways (for instance from a control room, by a local switch or externally by a testing device) depending on the testing condition. The several time measurement triggers are available to record a measurement in a various testing condition:

- external trigger
- analog channels
- auxiliary channels
- coil control channel

The **auxiliary inputs** are used to monitor dry and wet auxiliary contacts.

Built-in micro-ohmmeter (up to 500 A optional feature) provides high current for single phase dynamic and static resistance measurement, as well as for BSG timing measurement of **Dead tank** circuit breakers.

The additional six **voltage analog channels** have four selectable voltage ranges available (± 1 V, ± 5 V, ± 60 V and ± 300 V AC/DC). They are used to monitor:

- Measurement of coil resistance (simultaneously for 3 coils – during open or close sequence)
- Circuit-breaker substation battery voltage,
- DC and AC currents during the “**First trip**” test,
- Other types of analog signals which may be relevant.

Vibration channels record circuit breaker vibrations.

Three transducer channels provide measuring displacement of the circuit breaker moving parts,

contact wipe, over-travel, rebound, damping time and an average velocity. Either an analog or a digital transducer can be connected to these universal channels.

Test results are printed on the 112 mm (4.4 inch) **thermal printer (optional feature – excludes Minimum trip voltage test)** in tabular and graphical form.

Built-in capability to perform **Minimum trip voltage test (optional feature – excludes thermal printer)** to ensure that a circuit breaker open and close coil can reliably work with a minimum tripping voltage much below the nominal battery voltage in accordance with international standards (IEC 62271-100, ANSI C37.09 etc.)

Application

The list of the instrument applications includes:

- Simultaneous timing, static resistance and dynamic resistance measurement on up to 12 main contacts chambers under BSG conditions by use of CAT modules
- Simultaneous timing measurement of up to 12 main contacts (4 breaks per a phase – depending on model) including pre-insertion resistors (if present in the circuit breaker) and 6 auxiliary contacts,
- A resistance measurement of the pre-insertion resistors (if present in the circuit breaker)
- An evaluation of synchronization between the circuit breaker poles
- Measurement of the coil currents, voltages and resistance simultaneously for 6 coils
- Evaluating the state of substation’s batteries by graphically showing the voltage value
- Measurement of displacement, contact wipe, over-travel, rebound, damping time and average velocity of the breaker’s moving parts
- Recording of circuit breaker vibrations
- Anti-Pumping relay test
- “First trip” test
- Single phase static resistance measurement
- Single phase dynamic resistance measurement
- Minimum operating voltage test
- Measurement of spring-charging motor time, current and voltage (both DC and AC power supply voltage, when coupled with DV Power Coil Analyzer SAT II series to create one test system (control and testing done with CAT500 touch screen interface))

Features



1 - Mains power supply input

90 – 264 V AC; 50 Hz – 60 Hz

2 – On/Off switch

3 - Thermal printer (optional) (Built-in 112 mm (4.4 inch) wide) Graphic and numeric printout of contact and travel wave form

4 - Auxiliary inputs

Used for timing measurement of dry or wet auxiliary contacts

5 - Analog channels inputs

Used for voltage measurement of an analog signal that may be relevant.

6 - Current clamps voltage supply

24 V voltage output for current clamps

7 - Motion transducer inputs

Intended for measuring displacement of circuit breaker's moving parts

8 - Main contacts inputs

Used for timing of the main and pre-insertion resistor contacts, and for the resistance measurement of the pre-insertion resistors

9 Vibration channels inputs Intended for circuit breaker vibrations measurement

10 - Coil control outputs & external trigger input

Used for operating the circuit breaker OPEN and CLOSE coil, External trigger feature or Minimum Trip voltage test.

11 - Coil supply input

Separated voltage supply inputs for open and close coil control

12 – Earth (ground) terminal

13 - Micro Ohmmeter (optional) (built-in micro ohmmeter – up to 500 A DC) for single-phase static and dynamic contact resistance measurement

14 – START button

Used to start the test

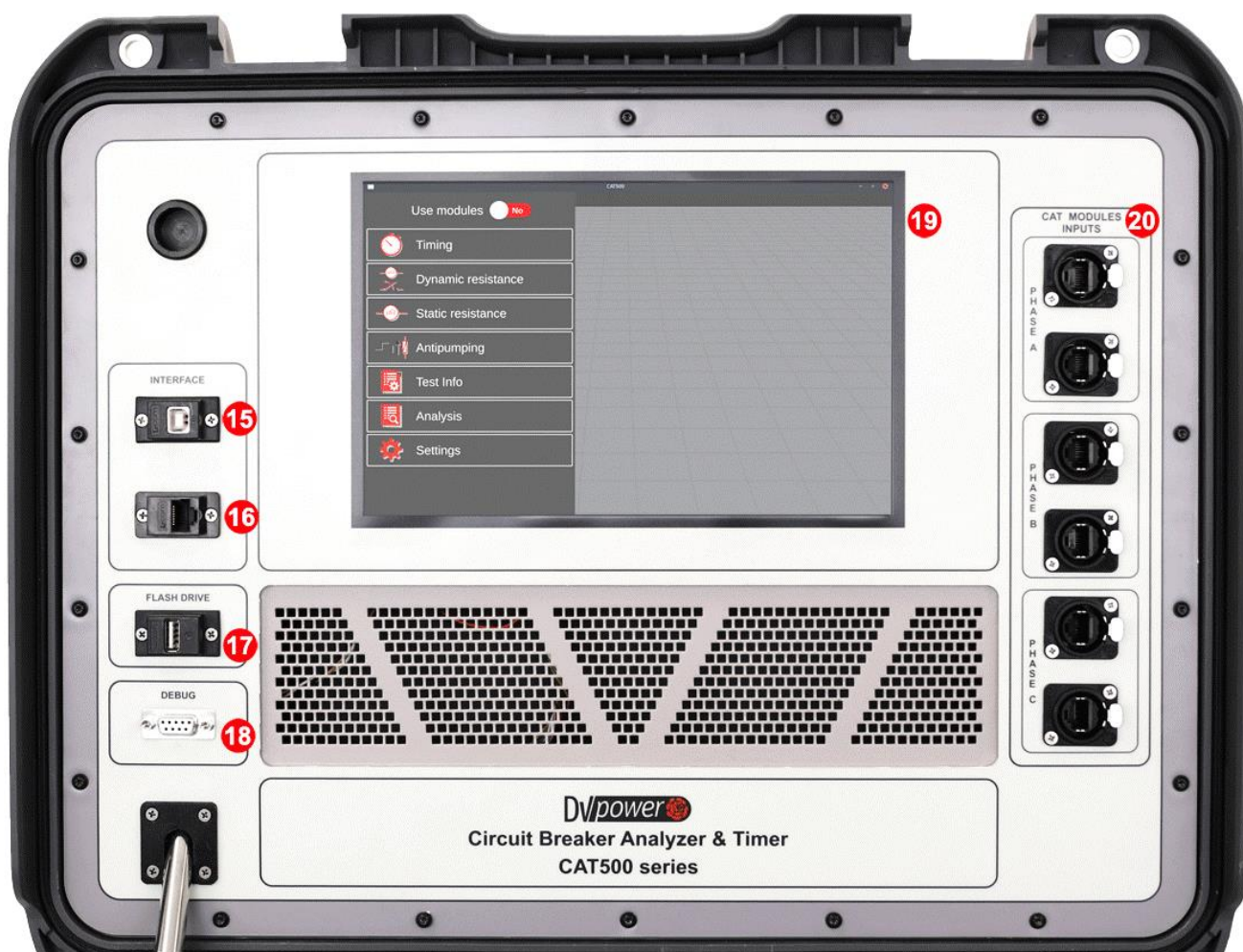

15 - PC communication
USB interface

16 – PC communication Ethernet interface

17 - Flash drive
Used for a direct download of test results on a USB memory stick.

18 – Debug input
Used for upload of updated user interface version

19 – Touch-screen color display (10.1 inch)
provides easy and intuitive control of test device and result analysis.

20 – CAT Module inputs
Used for simultaneous dynamic resistance, static (contact) resistance and timing measurement of the main arcing contacts

Touch Screen Interface

New powerful touch screen interface enables control of all the CAT500 series functions. It supports measurements process and intuitive step by step guidance through the entire test procedure, providing faster and easier testing. All test parameters and settings tools are clearly displayed and can be easily defined or modified.

Test results evaluation is supported on-site through numerical and graphical presentation. Graphical presentation of a variety of measurements, timing and dynamic resistance test results uses cursors and powerful zoom functions for detailed analysis.

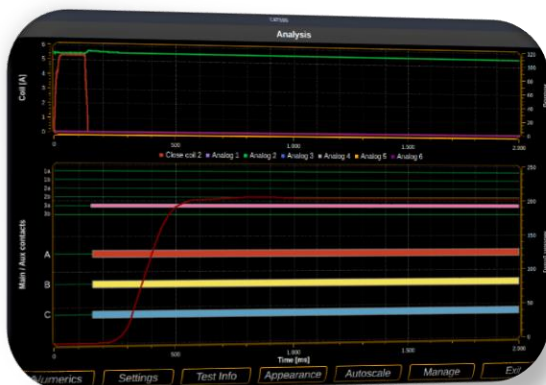
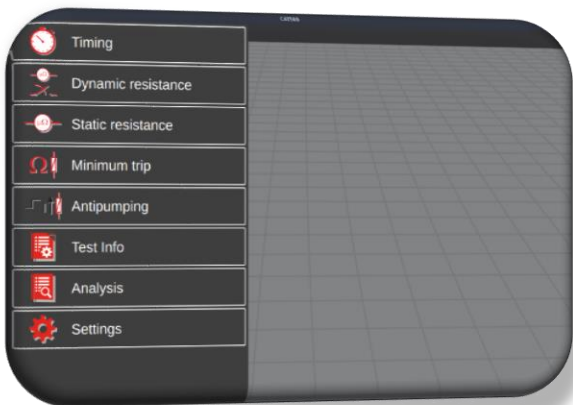

Simultaneous timing, static (contact) resistance and dynamic resistance measurement on Live Tank Circuit Breakers

Both Sides Grounded (BSG) feature of AIS (Air Insulated Substation) Live Tank circuit breakers enables safe and fast testing in high voltage substations, without removing the safety ground connections on both sides of the circuit breaker.

Utilizing optional **CAT modules**, CAT500 simultaneously records timing, contact resistance and dynamic resistance measurement for up to 12 interrupting chambers during circuit breaker operation, even under both sides grounded conditions.

One CAT Module can connect to two circuit breaker main contacts interrupting chambers. In order to simultaneously measure a three-phase circuit breaker with two interrupting units per phase, three CAT Modules are required.

CAT Module can generate up to 100 A per output. Ethernet communication system provide faster data acquisition and simultaneous charging of the internal battery before test initiation.

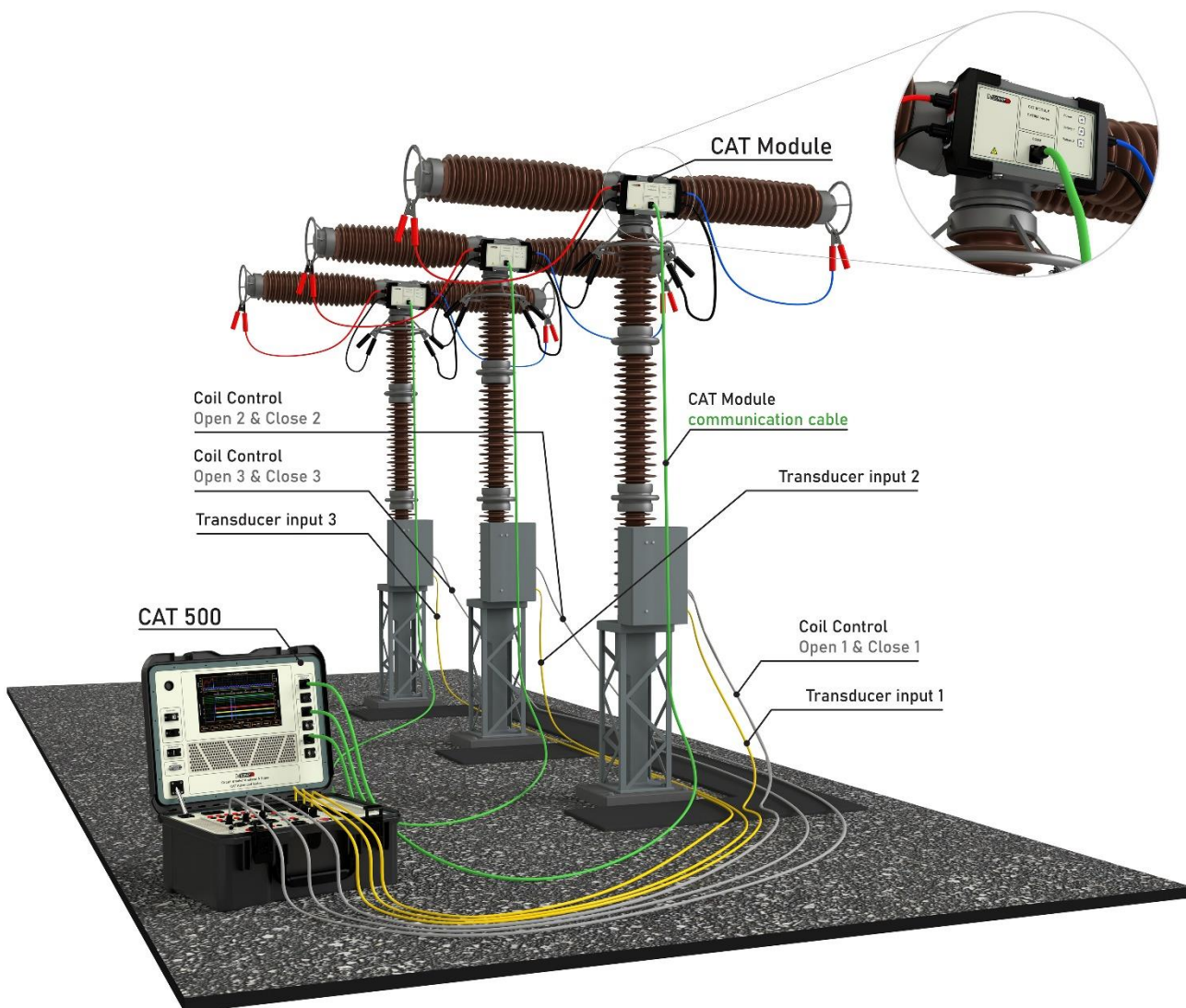

Simultaneous timing, contact resistance and dynamic resistance measurement of up to 6 interrupting chambers

(2 breaks per phase)

Timing measurement

Timing measurement of the mechanical operations is one of the most important tests to determine real condition of the circuit breaker. Timing measurement tests fulfill all the requirements defined by IEC 62271-100 and IEEE C37.09.

In three-phase systems, not only the contacts in a single pole have to operate simultaneously, but all poles must also operate at the same time. All contacts must be synchronized, within a certain tolerance limit.

Auxiliary contacts are mechanically driven by the operating mechanism and are used for control and indication of main contacts' state. There are no general requirements, related to timing measurement of auxiliary contacts, described in IEC® and IEEE® standards. Anyway, in order to assess condition of high-voltage circuit breakers, it is important to check their operation.

Simultaneous timing measurement

CAT500 simultaneously assesses the timing of all main contacts, pre-insertion resistors contacts and auxiliary contacts.

It measures the synchronization between the circuit breaker poles and can detect incorrect mechanical adjustments or wear phenomena of the circuit breakers.

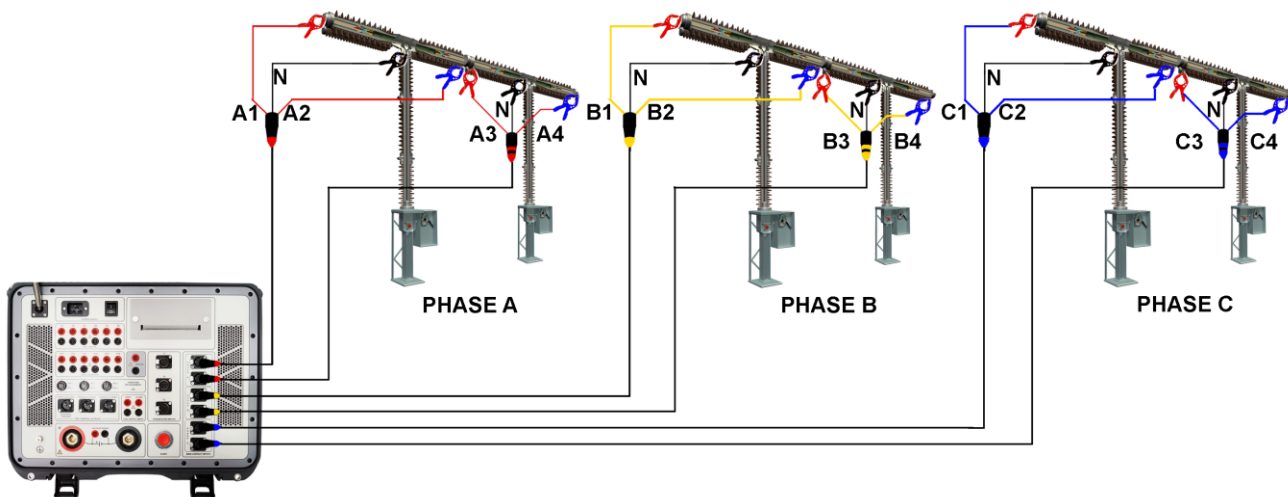

Conventional timing measurement – main contact timing cables connection to a live tank circuit breaker (4 breaks per phase)

Timing measurement under Both Sides Grounded conditions on Dead Tank Circuit Breakers

This feature is used for timing measurement of Dead Tank circuit breakers contact time with **any type of grounding system** being applied to both sides of the bushings.

Method is based on the DC current generation through the main circuit and measurement voltage or current response on the CT secondary during CB operation.

Built-in micro-ohmmeter (up to 500A optional feature) is used as a DC current source.

A connection from a current source to circuit breaker terminals is performed with current cables which further branch each in three cables, providing in that way the equal current distribution through all three main contacts.

The AC transformer based current probes are connected to accessible CT secondary terminals. The current AC probes will detect a change in the response signals when the circuit breaker contact is opened or closed.

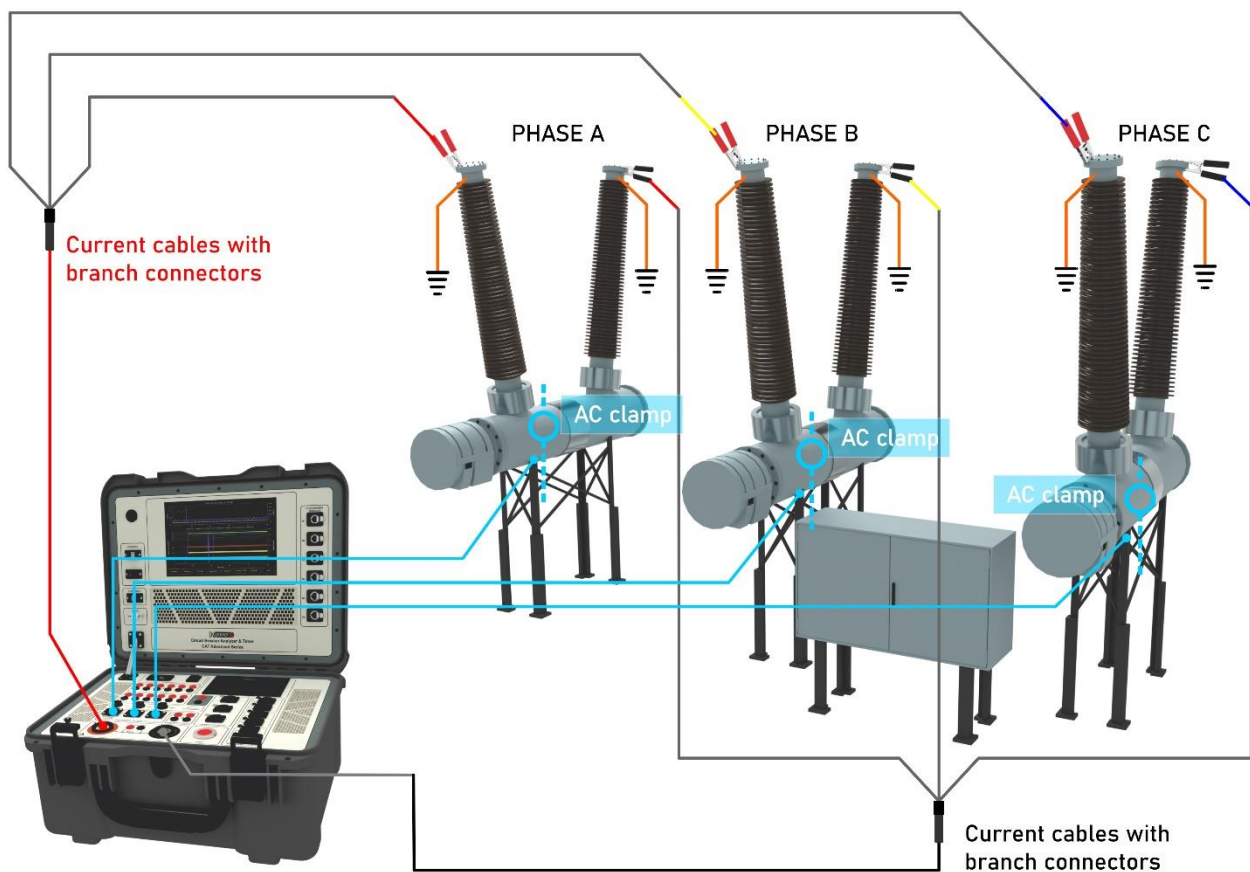

Timing measurement under Both Sides Grounded conditions on Dead Tank Circuit Breakers

Timing measurement under Both Sides Grounded conditions on GIS (Gas Insulated Switchgear) – Coming soon

Both Sides Grounded (BSG) of GIS (Gas Insulated Substation) feature enables timing measurement of three-pole and single-pole controlled GIS contact time without having to remove detachable shunts for grounding of GIS circuit breaker terminals.

The method is based on the DC current generation through the main circuit and measurement of the transition changes of the supplying DC current or current response on the CT secondary during CB operation using the GIS Test Module.

GIS Test Module is used as an independent DC current source with three separate current outputs (up to 400 A per current output), one for each phase.

A connection from a current source to circuit breaker terminals is performed with current cables through all three main contacts.

The AC transformer based current probes are connected to accessible CT secondary terminals. The current AC probe inputs of **GIS Test Module** will detect a change in the response signals when the circuit breaker contact is opened or closed.

For GIS circuit breakers with the CTs placed outside of the grounding switch circuit, there is no point in connecting AC current probes and in that case the transition changes of the supplying DC current will be measured directly inside the GIS test module.

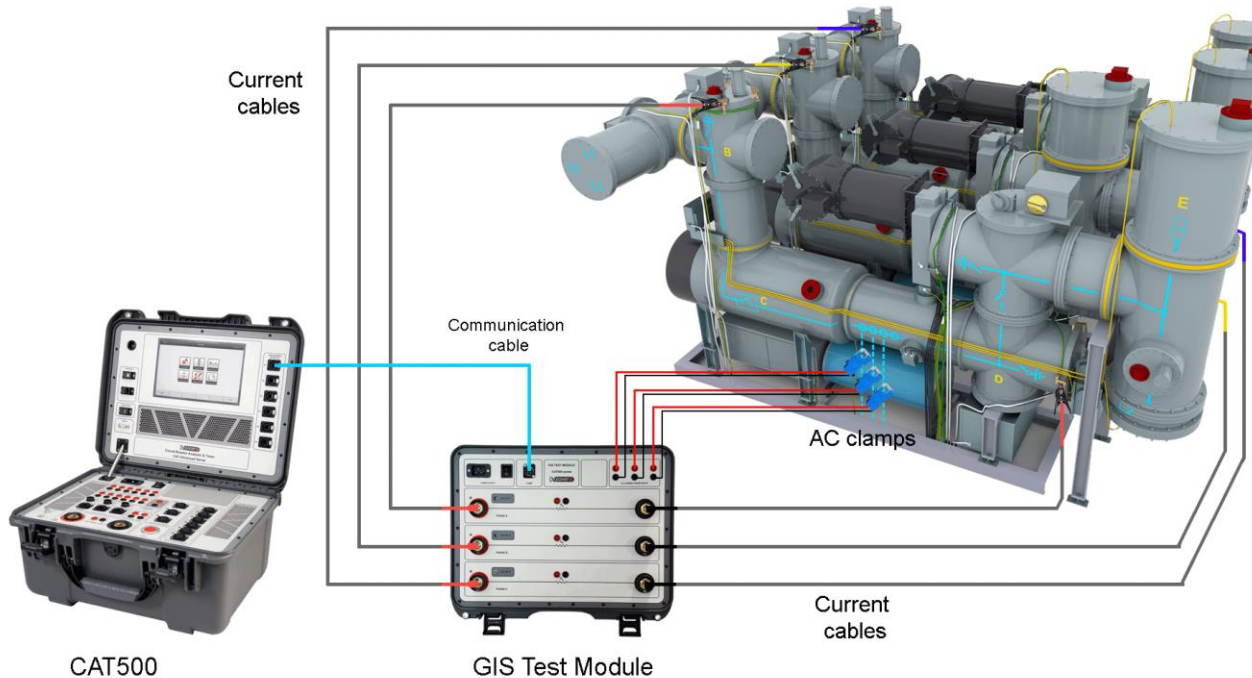

Timing measurement of single-pole controlled GIS under BSG conditions with use of GIS Module

Motion measurement

Motion measurement of the high voltage circuit breakers' contact system is of crucial importance for assessing the condition of the test object. The three motion transducer channels can acquire data from 3 linear or rotary motion transducers. Each channel can be configured for either an analog or a digital transducer.

Due to universal transducer channels design, a user can connect to a variety of motion transducers available on the market.

Performance values such as: **stroke, over-travel, rebound, contact wipe** are obtained as a result of the measurement.

Users are usually allowed to mount transducers on accessible parts of the circuit breaker's mechanical linkage. Beside this, instrument often records rotary motion, even it is known the main contacts motion is linear. As a result, motion results obtained do not represent real movement of the main contacts, but just linear or nonlinear interpretation of the main contacts moving parts displacement.



Digital rotary transducer mounted on ABB LTB 245 kV SF6 circuit breaker

DV-Win software provides a transfer function feature which allows user to define linear or non-linear parameters in order to obtain actual displacement values of the main contact moving parts.

Coil current measurement

The IEC 62271-100 standard states that it is desirable to record the coil currents waveform, since it provides information about coils' condition (e.g. increased friction of the plungers, burned insulation, short-circuited part of the winding), the

latch for release of the operating mechanism (e.g. increased friction) and the operating mechanism (e.g. if there is reduced operating mechanism speed that can be seen based on the opening time of auxiliary contacts).

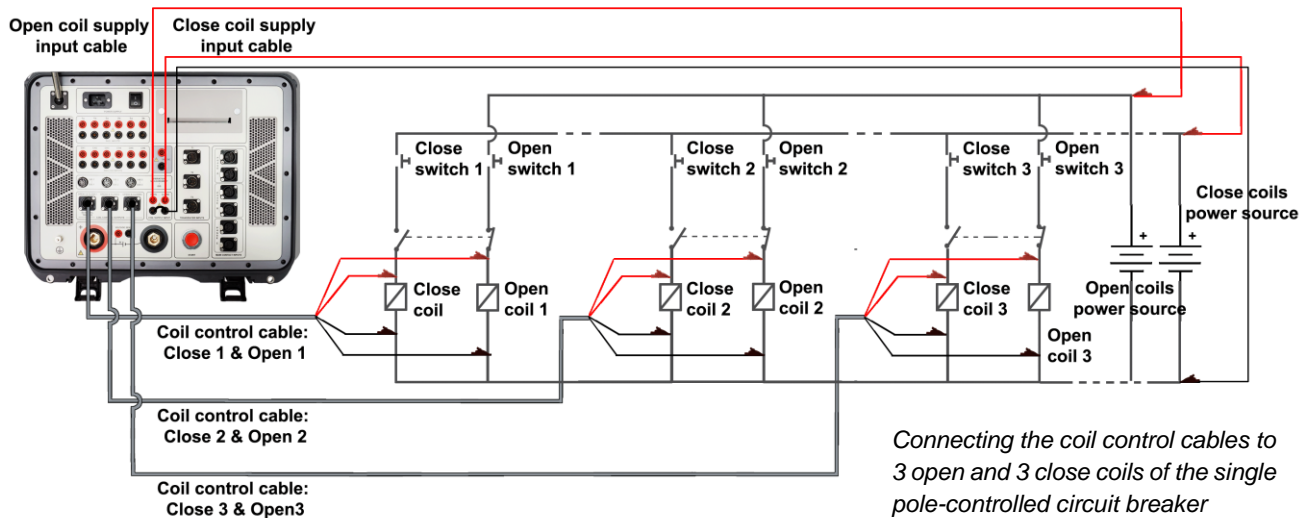

Connecting the coil control cables to 3 open and 3 close coils of the single pole-controlled circuit breaker

Single-phase static resistance measurement

Beside above-mentioned simultaneous static (contact) resistance measurement for up to 12 interrupting chambers available with CAT Modules, CAT500 can have either 200 A or 500 A built-in single phase micro ohmmeter, as an optional feature. Incorporated micro ohmmeter generates true DC ripple free current with an automatically regulated test ramps.

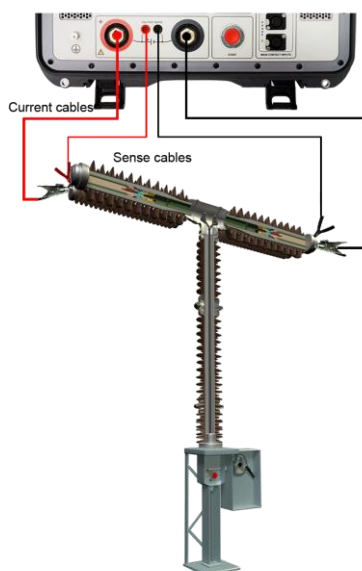

Micro Ohmmeter cable connection on a live tank circuit breaker

The resistance measurement is using the well-known Kelvin's four point's method.

The DC current is generated through the closed circuit breaker contacts. Voltage drop is measured between terminals of the circuit breakers. The resistance is calculated using the Ohm's law $R=U/I$.

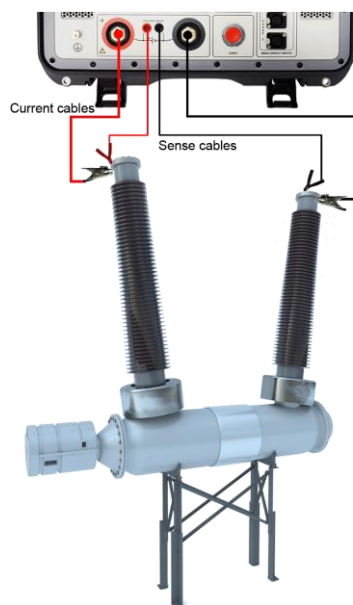

Micro Ohmmeter cable connection on a dead tank circuit breaker

High – Precision module (built-in)

The high-precision module is an optional built-in feature as an addition to the micro ohmmeter. It provides an increased precision and offers a highly accurate contact resistance measurement in the range from 1 $\mu\Omega$ to 30 $\mu\Omega$, with 0,01 $\mu\Omega$ resolution.

The CAT500 with the built-in High Precision Module may be used for applications on very low resistance measurements of non-inductive test objects. This requirement is usually met at resistance inspections of generator circuit breakers, welding joints, GIS enclosure joints etc.

DRM (Dynamic Resistance Measurement)

The built-in micro ohmmeter can also be used for single-phase DRM. DRM test is performed by injecting a current through the breaker contact and simultaneously monitoring the voltage drop across the breaker contact as well as the current flow during the breaker operation. The DRM test requires the circuit breaker analyzer with a high resolution measurement.

The resistance curve, as a function of a contact travel can be used to reveal potential problems related to the arcing contact condition. The injected current value should be as high as possible but no less than 100 A, to provide a reliable voltage drop reading, thus allowing easier detection of the arcing contact.

First trip test

“First trip” analysis is important to determine the condition of the coil operating mechanism. Circuit breaker spends most of its lifetime conducting a current without any operation. Once the protective relay detects a problem, the circuit breaker, that was idle for maybe a year or longer, has to operate as fast as possible. However, if the circuit breaker has not been operated for a long time, the friction of the trip latch release mechanism may increase. Information about the latch friction, open circuit contacts, insufficient spring tension, can be learned from the coil

current waveform recorded during the “**First trip**” test.

Since the breaker is in service, the conventional way of off-line timing measurement with timing cables across the interrupter cannot be used. Instead of main contact timing cables, three current probes are used. These current probes show current flowing through the secondary side of the current transformer for each phase. The instant when the current stops flowing, reveals the breaker open time.

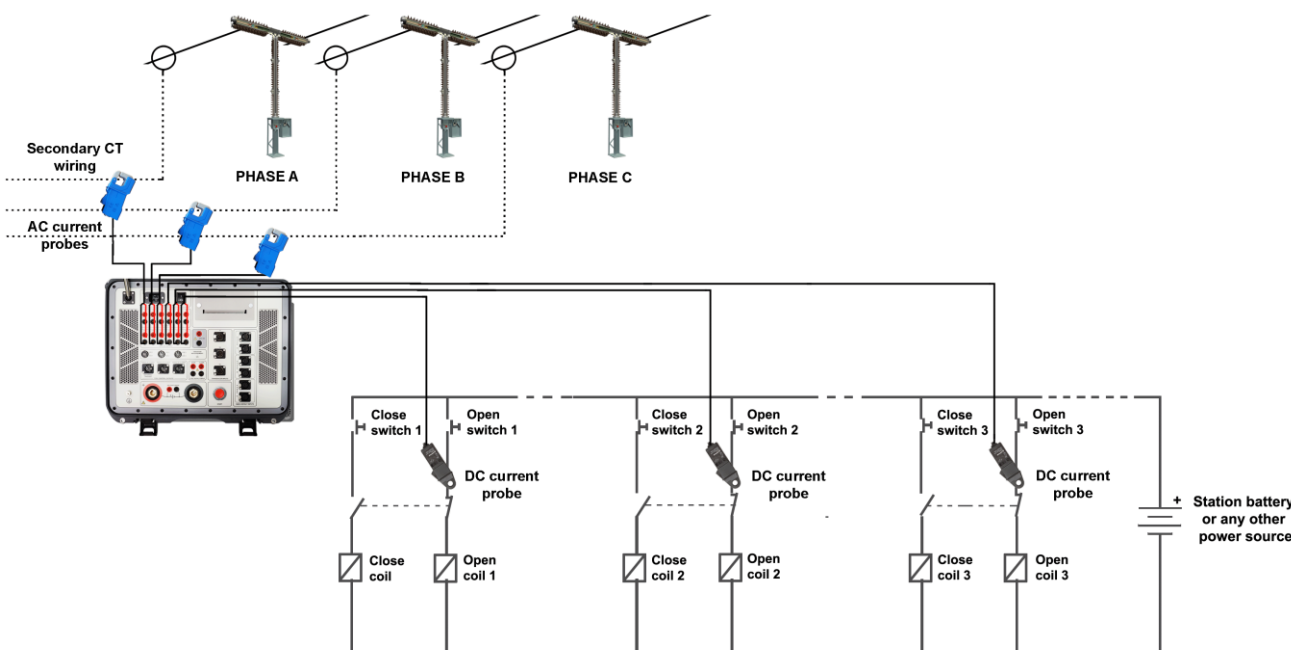

Connecting the DC current probes for measurement of the coil current and AC current probes to the line currents during the “First trip” test

DV-CB software

Acquisition and Analysis

DV-CB software provides acquisition and analysis of the test results, as well as control of all the CAT500 series functions from a PC. It supports measurements process and step by step guidance through the entire test procedure, providing faster, easier and safer testing.

Graphical presentation

Graphical presentation of a variety of measurements and timing test results uses cursors and powerful zoom functions for detailed analysis. Colors, grids, scales and positioning of the test data are all controlled by the user. DV-CB supports automatic unit conversion (e.g.: cycles to seconds or mm to inches). The test records can be exported in **.dwc** file format for further analysis.

Database

Results are automatically stored and organized in the database on your PC and are available for analysis and reporting. Each test can be automatically assessed according to manufacturer specifications or based on your individual limit values.

DV-CB software database can be updated with over 500 test plans of different apparatus commonly used in most utilities and substations. This valuable benchmark data used for test results evaluation is provided upon request.

Reports

DV-CB automatically generates reports including all asset-related information and performed tests. This gives you a comprehensive overview of the test object, test results and assessment. You can easily adapt test reports, for example, by choosing from different types of result tables and diagrams and by providing comments on every test. Furthermore, you can incorporate your company logo, photos and other test results.

- Full control of the CAT functions from a PC
- Downloading the test results from the instrument
- Acquisition and analysis of the test results
- The test results can be viewed, edited, saved, printed and exported
- Viewing and overlaying several graphs, for an easy test result comparison
- Selecting the measurement points and intervals using the two cursors
- Zoom and pan graph feature
- Specific test sequence setup
- Creation of predefined test plans for an easy and quick field testing
- Customized configuration of the test result graphs

Technical data

CAT Module

- Number of channels: 2
- Battery Li-Po: 2 200 mAh, 7.4 V
- Max current per channel: 100 A DC
- Static resistance range: 0,1 $\mu\Omega$ – 3 000 m Ω
- Dynamic contact res. range: 10 $\mu\Omega$ – 200 m Ω
- Maximum sample rate: 40 kHz
- Minimum resolution: 25 μs
- Communication: digital

Main contact inputs

- Number of contact inputs: up to 12 (3 x 4), 4 per phase, depending on the model
- Each channel detects main and pre-insertion resistor contacts.
 - Closed \leq 10 Ω ,
 - Resistor contacts range 10 Ω to 5 k Ω ,
 - Open \geq 5 k Ω
 Open circuit voltage: 20 V DC
 Short circuit current 50 mA
- Each channel measures resistance of pre-insertion resistors

Time measurement

Time measurement resolution:

- 0.025 ms for 1 s test duration (sampling rate 40 kHz)
- 0,1 ms for 2 s test duration (sampling rate 10 kHz)
- 1 ms for 20 s test duration (sampling rate 1 kHz)
- 10 ms for 200 s test duration (sampling rate 100 Hz)

Time accuracy \pm 0,05% of the reading \pm resolution

Auxiliary inputs

- Number of channels: 6, galvanically isolated
- User selectable: dry or wet
- Contact sensing (dry):
Open circuit voltage 24 V DC,
Short circuit current 5 mA
- Voltage sensing (wet):
Working voltage 300 V DC, 250 V AC
Low activation mode \pm 5 V
High activation mode \pm 10 V
- Overcurrent and overvoltage protection

Coil driver

- Number of channels: 6 (3 open and 3 close coil)
- 6 separate outputs for coil triggering
- Driver characteristics: 300 V DC max, 35 A DC max
- Electronic drivers: it provides superior timing control
- Overcurrent and overvoltage protection
- Coil supply inputs for open and close coil: 300 V DC max, 35 A DC max

Breaker operation

- Close (C)
 - Open (O)
 - Close-Open (C-O)
 - Open-Close (O-C)
 - Open-Close-Open (O-C-O)
 - First trip test
- User can select any desired test sequence

Current measurement

- Current measurement for Open and Close coil, 6 channels, Hall-Effect sensor
- Range \pm 35 A AC/DC to 5 kHz
- Accuracy \pm (0,5 % rdg + 0,1 % FS)
- Graphic presentation: currents waveform is displayed with resolution of 0,1ms

Coil resistance measurement

- 3 coils simultaneously (Open or Close)
- Measuring range / Resolution
1 Ω - 99,9 Ω / 0,1 Ω
100 Ω – 999 Ω / 1 Ω
- Typical accuracy \pm (0,5 % rdg + 0,5 % FS)

Universal transducer inputs

- 3 digital travel transducer channels
Digital rotary transducers: 2500ppr
- 3 analog travel transducer channels
- Analog transducer input measurement resolution: 16 bit.
- Internal supply for linear transducer: 5 V DC

Time measurement triggers

- External trigger: 2 channels (Open 1 & Close 1), input voltage: 10 V – 300 V AC/DC
- Coil currents: threshold level user selectable
- Auxiliary inputs
- Analog inputs: threshold level user selectable

Analog inputs

- 6 channels – Coil current measurement
- 6 Voltage channels, each channel has four measurement ranges: ± 1 V, ± 5 V, ± 60 V and ± 300 V AC/DC

The analog inputs are isolated with respect to all other circuits

Vibration channels inputs

Intended for circuit breaker vibrations measurement

- 3 channels – for vibration monitoring sensors

GIS channels inputs

Intended for BSG timing measurement feature of GIS (Gas Insulated Substation) circuit breakers

- 3 channel inputs for **AC** current clamps

DC output

- 24 V voltage supply for current clamps

Static resistance measurement

- Built-in Micro Ohmmeter (200 A or 500 A)
- Current range 5 A – 200 A / 500 A
- Max. load voltage 6,2 V
- Resistance range 0,1 $\mu\Omega$ - 999,9 m Ω
- Resolution 0,1 $\mu\Omega$
- Accuracy \pm (0,1 % rdg + 0,1 % FS)

Dynamic resistance measurement

- Voltage and current measuring channels
- DRM sampling rate 40 kHz (0.025 ms time resolution)
- Resolution 16 bit
- Breaker operations available for DRM test:
 - Open (O)
 - Close (C)
 - O – C (auto reclose)
 - C – O (make brake)
 - O-CO

Printer (optional)

- Thermal printer
- Graphic and numeric printout
- Paper width 112 mm / 4.4 in
- Excludes Minimum trip voltage module option

The print density is guaranteed within range: 5°C to 40°C, 20 to 85% relative humidity, non-condensing

Minimum trip voltage module (optional)

- Operating voltage: 10V – 300 V DC
- Adjustment step: 1 V
- Excludes built-in thermal printer option

Warranty

- 3 years' warranty + 1 additional year after registration on www.dv-power.com

Dimensions and weight

- Dimensions (L x W x H):
505 mm x 409 mm x 257 mm
19.9 in x 16.1 in x 10.1 in
- Weight: from 15,5 kg (34.1 lbs) up to 17 kg (37.4 lbs) depending on built-in features

Mains power supply

- Connection according to IEC/EN60320-1; UL498, CSA 22.2
- Mains supply: 90 V - 264 V AC
- Frequency: 50/60 Hz
- Input power:
 - 250 VA (without use of Micro Ohmmeter)
 - 1900 VA (with use of Micro Ohmmeter 200 A)
 - 3900 VA (with use of Micro Ohmmeter 500 A)

Applicable Standards

- Installation/overvoltage: category II
- Pollution: degree 2
- Safety: LVD 2014/35/EU (CE Conform)
Standard EN 61010-1
- EMC: Directive 2014/30/EU (CE Conform)
Standard EN 61326-1:2006
- CAN/CSA-C22.2 No. 61010-1

Environmental conditions

- Operating temperature: -10 °C - +55 °C / 14 °F - +131 °F
- Storage & transportation: -40 °C - +70°C / -40 °F - +158 °F
- Humidity 0 % - 95 % relative humidity, non-condensing

*All specifications herein are valid at ambient temperature of + 25 °C and standard accessories.
Specifications are subject to change without notice.*

Accessories



CAT Module - for timing, static and dynamic resistance measurement recording
CAT-MODUL-00



Current and sense cables 2 x 3,5 m (red) with SCT clamps
CSR-3Z5-15NCST



Current and sense cables 2 x 1,5 m (black) with SCT clamps
CSB-1Z5-15NCST



Communication cable 1 x 20 m for CAT module
C1-0020-RXX6



Main contact cables 5 m with SCT clamps (12 channels)
CM-05-12MXST



Main contact cables 5 m with SCT clamps (6 channels)
CM-05-65MXST



Main contact cables 5 m with SCT clamps (3 channels)
CM-05-34MXST

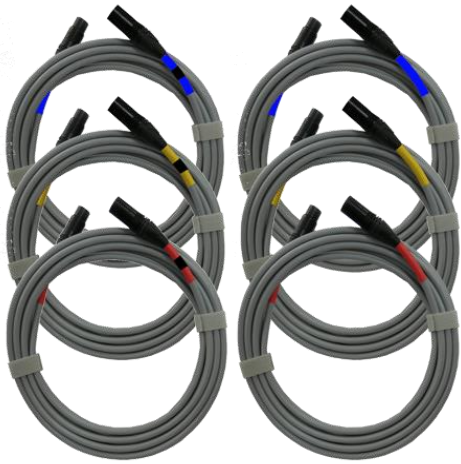

Main contact cables extension 10 m (12 channels)
E6-10-12MXFX

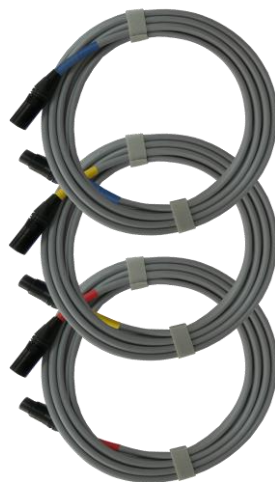

Main contact cables extension 10 m (3 or 6 channels)
E3-10-65MXFX



Coil supply cable set 4 x 5 m 2,5 mm² (16.4 ft, 13 AWG) with banana plugs



Coil control cable set 5 m with banana plugs (Single-pole control - 6 coil channels)
CO-05-6BC5B1



Coil control cable 5 m with banana plugs (Three pole control - 2 coil channels)
CO-05-00C5B1



Auxiliary contacts cable set 12 x 5 m with banana plugs
AX-05-02BPBP



Analog channels cable set 12 x 5 m with banana plugs
AN-05-02BPBP



Current cables 2 x 10 m 25 mm² with battery clamps (B1) (200 A rated)
C2-10-25LMB1



Current cables 2 x 10 m 50 mm² with battery clamps (B3) (500 A rated)
C2-10-50VMB3



Sense cables 2 x 10 m with alligator clamps (A2)
S2-10-02BPA2



Plastic transport case with wheels
– large size
PLCAS-P00-W3



Plastic case for CAT modules
(up to 2 breaks)
PLCAS-CAT-03



Cable plastic case - medium size
CABLE-CAS-02



Cable plastic case with wheels -
large size
CABLE-CAS-W3



Cable bag
CABLE-BAG-00



Current clamp 30/300 A power
supplied from the instrument with
adapter 5 m
CACL-0300-07



AC Current clamp 1 A / 1 V and
cable 5 m with banana plugs
CACL-ACBP-05



Test Shunt 600 A / 60 mV
SHUNT-600-MK



Digital rotary transducer with 5 m
connection cable with accessories
DRT-SET-0005



Linear analog transducer (TLH) 225
mm with 5 m connection cable
LAT-225-C305



Doble transducer adapter
DTA-BOX-C002



**Universal transducer mounting kit
UTM-KIT-0000**

**Universal transducer mounting
kit - extended version
UTM-KIT-0001**

**Three phase digital rotary transducer
kit (with 5 m connection cable)
TPH-DRTS-050**



**Online first trip test kit – three-pole
control
ONFTT-KIT-01**

**Online first trip test kit – single-
pole control
ONFTT-KIT-00**

*The above cables are also available in several lengths and terminations.
The above linear analog transducers are available in several lengths.
Please contact DV Power for more information.*

CAT500 series - models

CAT500 with 3 timing channels

	<p>Main contact inputs Number of contact inputs: 3 (3 x 1), 1 per phase</p> <p>Auxiliary contact inputs: 6</p> <p>Analog contact inputs: 6</p> <p>Coil control outputs: 6</p> <p>Transducer inputs: 3</p>	<p>Optional:</p> <p>Static resistance measurement (built-in) Built-in Micro Ohmmeter 200 A Built-in Micro Ohmmeter 500 A</p> <p>High precision module (built-in)</p> <p>Thermal printer 112 mm (built-in)</p> <p>Minimum trip voltage module</p>
--	--	--

CAT500 with 6 timing channels

	<p>Main contact inputs Number of contact inputs: 6 (3 x 2), 2 per phase</p> <p>Auxiliary contact inputs: 6</p> <p>Analog contact inputs: 6</p> <p>Coil control outputs: 6</p> <p>Transducer inputs: 3</p>	<p>Optional:</p> <p>Static resistance measurement (built-in) Built-in Micro Ohmmeter 200 A Built-in Micro Ohmmeter 500 A</p> <p>High precision module (built-in)</p> <p>Thermal printer 112 mm (built-in)</p> <p>Minimum trip voltage module</p>
--	--	--

CAT500 with 12 timing channels

	<p>Main contact inputs Number of contact inputs: 12 (3 x 4), 4 per phase</p> <p>Auxiliary contact inputs: 6</p> <p>Analog contact inputs: 6</p> <p>Coil control outputs: 6</p> <p>Transducer inputs: 3</p>	<p>Optional:</p> <p>Static resistance measurement (built-in) Built-in Micro Ohmmeter 200 A Built-in Micro Ohmmeter 500 A</p> <p>High precision module (built-in)</p> <p>Thermal printer 112 mm (built-in)</p> <p>Minimum trip voltage module</p>
--	---	--

Order info

Instrument	Article No.
Circuit Breaker Analyzer & Timer CAT500 with 3 timing channels	CAT500-03-W3
Circuit Breaker Analyzer & Timer CAT500 with 6 timing channels	CAT500-06-W3
Circuit Breaker Analyzer & Timer CAT500 with 12 timing channels	CAT500-12-W3

Included accessories
Windows based DV-CB PC software
USB cable
Ethernet cable
Debug adapter
Mains power cable
Ground (PE) cable
Plastic transport case with wheels

Standard accessories	Article No.
Simultaneous timing, static (contact) resistance and dynamic resistance measurement	
CAT Module - for timing, static and dynamic resistance measurement recording (x3)	CAT-MODUL-00
Communication cable 1 x 15 m for CAT module (x3)	C1-0015-RXX
Current and sense cables 2 x 3,5 m (red) with SCT clamps for CAT Module (x3)	CSR-3Z5-15NCST
Current and sense cables 2 x 1,5 m (black) with SCT clamps for CAT Module (x3)	CSB-1Z5-15NCST
Control cabinet cables	
Coil control cable set 5 m (16.4 ft) with banana plugs (Single-pole control -6 coil channels)	CO-05-6BC5B1
Coil supply cable set 4 x 5 m 2,5 mm ² (16.4 ft, 13 AWG) with banana plugs	CS-05-02BPBP
Auxiliary contacts cable set 12 x 5 m (16.4 ft) with banana plugs	AX-05-02BPBP
Analog channels cable set 12 x 5 m (16.4 ft) with banana plugs	AN-05-02BPBP
Cases	
Plastic case for CAT modules (up to 2 breaks)	PLCAS-CAT-03
Cable plastic case - large size (x2)	CABLE-CAS-03

Optional accessories	Article No.
Micro ohmmeter 200 A (built-in)	BIMCAT5-2-00
Micro ohmmeter 500 A (built-in)	BIMCAT5-5-00
Minimum Trip Voltage Module (built-in, compatible with CAT250 and CAT500 Series excluding a thermal printer)	MTV-MODUL-00
Thermal printer 112 mm (4.4 inch) (built-in, excluding Minimum Trip Voltage Module)	PRINT-112-01
Thermal paper roll 112 mm (4.4 inch)	PRINT-112-RO
Built-in high precision measurement module	RMO-HPMM-DG0
Current clamp 30/300 A power supplied from the instrument with extension 5 m (16.4 ft) and adapter	CACL-0300-07
Current clamp 30/300 A with internal battery supply and extension 5 m (16.4 ft)	CACL-0300-08
AC Current clamp 1 A / 1 V with 5 m cable and adapter	CACL-ACBP-05
Main contact cables	
Main contact cables 5 m (16.4 ft) with SCT clamps (for three timing channels)	CM-05-34MXST
Main contact cables 5 m (16.4 ft) with SCT clamps (for six timing channels)	CM-05-65MXST
Main contact cables 5 m (16.4 ft) with SCT clamps (for twelve timing channels)	CM-05-12MXST
Main contact cables extension	
Main contact cables extension 5 m (16.4 ft) (for three or six timing channels)	E3-05-65MXFX
Main contact cables extension 5 m (16.4 ft) (for twelve timing channels)	E6-05-12MXFX
Main contact cables extension 10 m (32.8 ft) (for three or six timing channels)	E3-10-65MXFX
Main contact cables extension 10 m (32.8 ft) (for twelve timing channels)	E6-10-12MXFX
Main contact cables extension 15 m (49.2 ft) (for three or six timing channels)	E3-15-65MXFX
Main contact cables extension 15 m (49.2 ft) (for twelve timing channels)	E6-15-12MXFX
Control cabinet cables	
Coil control cable set 10 m with banana plugs (Single-pole control -6 coil channels)	CO-10-6BC5B1
Coil control cable set 15 m with banana plugs (Single-pole control -6 coil channels)	CO-15-6BC5B1
Coil control cable 5 m with banana plugs (Three-pole control - 2 coil channels)	CO-05-00C5B1
Coil control cable 10 m with banana plugs (Three-pole control - 2 coil channels)	CO-10-00C5B1
Coil control cable 15 m with banana plugs (Three-pole control - 2 coil channels)	CO-15-00C5B1
Auxiliary contacts cable set 12 x 5 m with banana plugs	AX-05-02BPBP
Auxiliary contacts cable set 12 x 10 m with banana plugs	AX-10-02BPBP
Auxiliary contacts cable set 12 x 15 m with banana plugs	AX-15-02BPBP
Analog channels cable set 12 x 5 m with banana plugs	AN-05-02BPBP
Analog channels cable set 12 x 10 m with banana plugs	AN-10-02BPBP
Analog channels cable set 12 x 15 m with banana plugs	AN-15-02BPBP
Cable cases	
Cable plastic case - medium size	CABLE-CAS-02
Cable plastic case with wheels - medium size	CABLE-CAS-W2
Cable plastic case - large size	CABLE-CAS-03
Cable plastic case with wheels - large size	CABLE-CAS-W3

Current cables	
Current cables 2 x 5 m 50 mm ² (32.8 ft, 0 AWG) with battery clamps (for built in 500 A micro ohmmeter)	C2-05-50VMB3
Current cables 2 x 10 m 50 mm ² (32.8 ft, 0 AWG) with battery clamps (for built in 500 A micro ohmmeter)	C2-10-50VMB3
Current cables 2 x 15 m 70 mm ² (49.2 ft, 00 AWG) with battery clamps (for built in 500 A micro ohmmeter)	C2-15-70VMB3
Current cables 2 x 5 m 25 mm ² (32.8 ft, 3 AWG) with battery clamps (for built in 200 A micro ohmmeter)	C2-05-25LMB1
Current cables 2 x 10 m 25 mm ² (32.8 ft, 3 AWG) with battery clamps (for built in 200 A micro ohmmeter)	C2-10-25LMB1
Current cables 2 x 15 m 35 mm ² (49.2 ft, 2 AWG) with battery clamps (for built in 200 A micro ohmmeter)	C2-15-35LMB1
Sense cables	
Sense cables 2 x 5 m (32.8 ft) with alligator clamps (for built in micro ohmmeter)	S2-05-02BPA1
Sense cables 2 x 10 m (32.8 ft) with alligator clamps (for built in micro ohmmeter)	S2-10-02BPA1
Sense cables 2 x 15 m (49.2 ft) with alligator clamps (for built in micro ohmmeter)	S2-15-02BPA1
Transducers	
Digital rotary transducer with 5 m (16.4 ft) connection cable	DRT-250-C605
Digital rotary transducer with 10 m (32.8 ft) connection cable	DRT-250-C610
Digital rotary transducer with 5 m (16.4 ft) connection cable with accessories	DRT-SET-0005
Digital rotary transducer with 10 m (32.8 ft) connection cable with accessories	DRT-SET-0010
Linear analog transducer 150 mm (5.9 in) with 5 m (16.4 ft) connection cable and linear transducer rod	LAT-150-C305
Linear analog transducer 225 mm (8.85 in) with 5 m (16.4 ft) connection cable and linear transducer rod	LAT-225-C305
Linear analog transducer 300 mm (11.8 in) with 5 m (16.4 ft) connection cable and linear transducer rod	LAT-300-C305
Linear analog transducer 500 mm (19.68 in) with 5 m (16.4 ft) connection cable and linear transducer rod	LAT-500-C305
Transducer mounting kits	
Universal transducer mounting kit	UTM-KIT-0000
Universal transducer mounting kit - extended version	UTM-KIT-0001
Doble transducer adapter	DTA-BOX-C002
Linear to rotary convertor	LTR-CON-0000
Online first trip test kit	
Online first trip test kit – single-pole control	ONFTT-KIT-00
Online first trip test kit – three-pole control	ONFTT-KIT-01
Plastic transport case	
Plastic transport case with wheels – large size	PLCAS-P00-W3

B-CAT500-101-EN

Date published: 2024-07-17

Subject to change without notice

IBEKO Power AB

Lejonstigen 9
181 32 Lidingö, Sweden

Contact

Phone: +46 70 0925 000
E-mail: sales@dv-power.com